



LD: Matthew J. Weisgabe	Carnegie Mellon University
ALD: Sasha Finley	Art: Philip Chosky Theatre
ALD: Eva Oney	REVISION
LM: Willem Hinternhoff	#1- 3/19/22
Assoc LM: James Gallo	#2 - 4/1/22
Assist LM: Ariel Bernhard	#3 - 4/13/22
EOS Progr: Alexa Janoschka	#4

VECTORWORKS EDUCATIONAL VERSION

MJW

LIGHTING DESIGN

HOUSE LIGHTS: 800
 CONDUCTOR: 502 + 503
 MUSIC STAND: 501

Spot 1 + R132

- 1- R3204
- 2- R3202
- 3- R302
- 4- R04
- 5- R333
- 6- R4730

Name: Philip

Spot 2 + R132

- 1- R3204
- 2- R3202
- 3- R302
- 4- R04
- 5- R333
- 6- R4730

Name: Leyla

Spot 3 -
Ground Control

Ch. 251

Name: Selina

Spot 4 -
Ground Control

Ch. 252

Name: Zachary

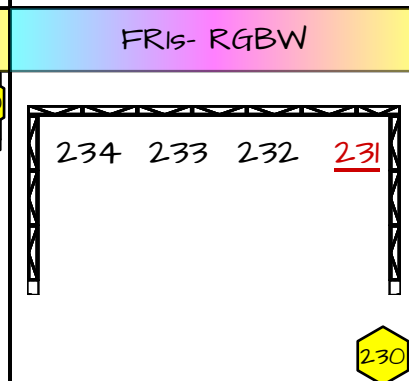
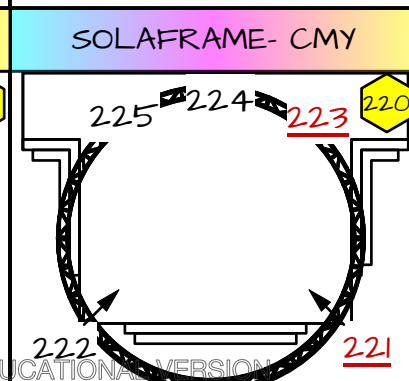
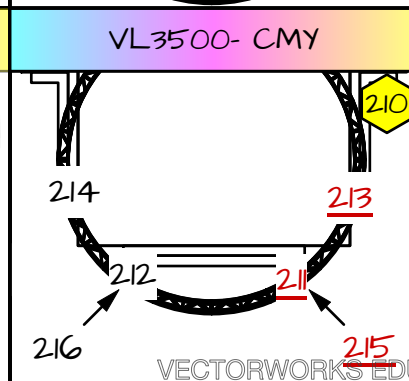
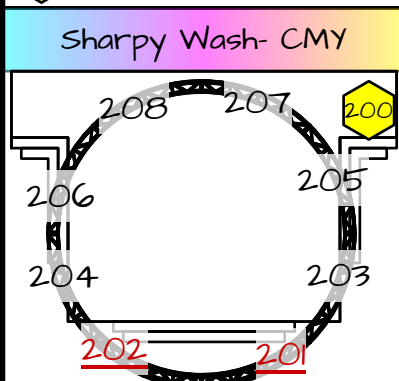
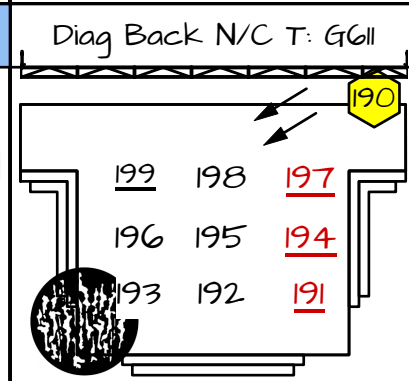
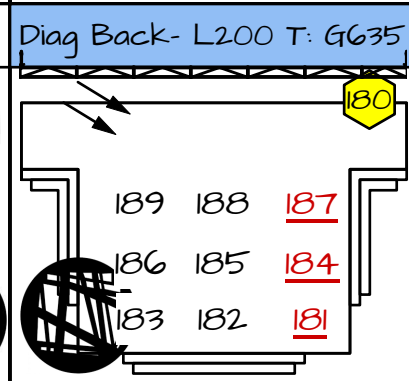
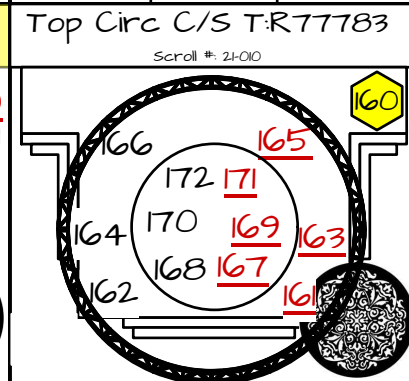
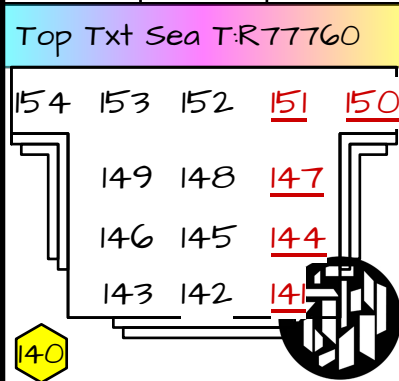
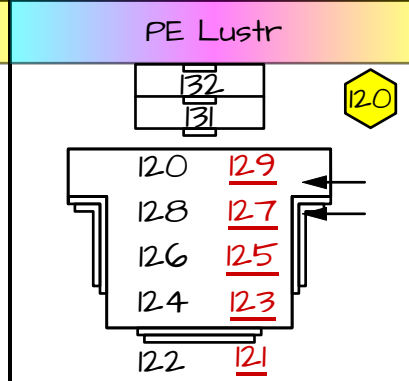
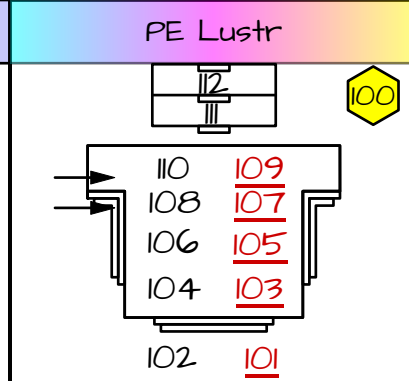
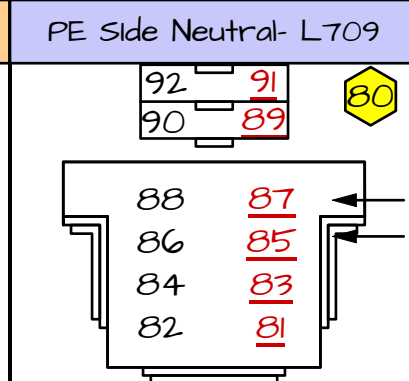
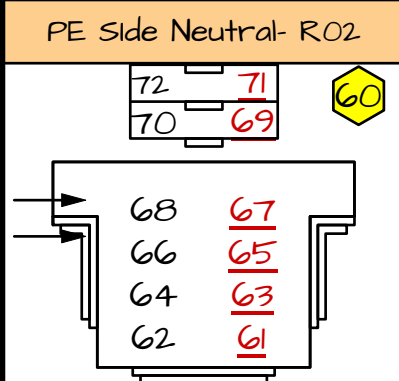
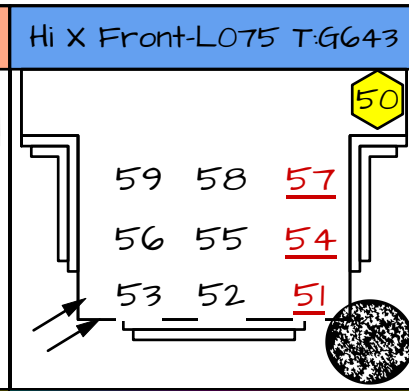
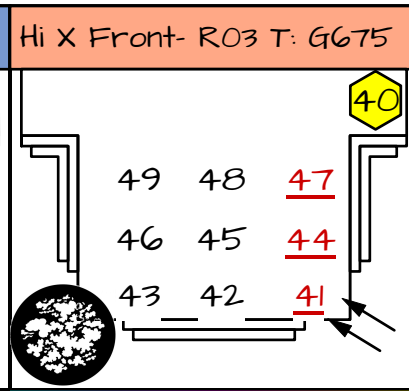
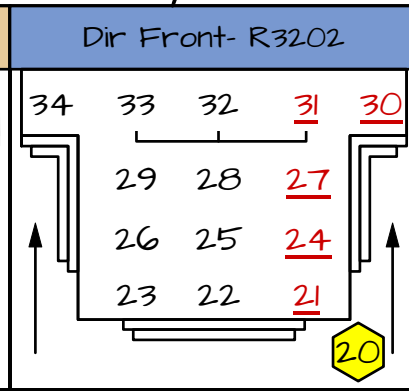
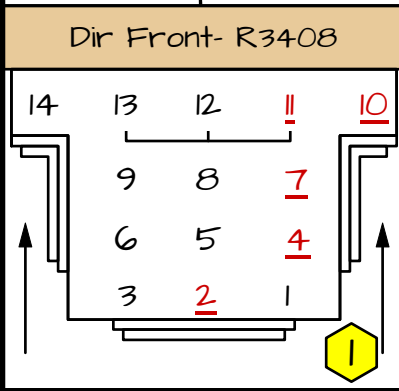

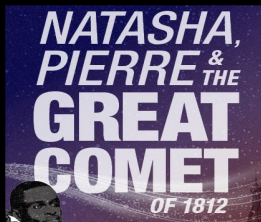

LD: Matthew J. Weisgale	Carnegie Mellon University
ALD: Sasha Finley	AT: Philip Chosky Theatre
ALD: Eva Oney	REVISION
LM: Willem Hinternhoff	#1 - 3/19/22
Assoc LM: James Gallo	#2 - 4/1/22
Assist LM: Ariel Bernhard	#3 - 4/13/22
EOS Progr: Alexa Janoschka	#4

VECTORWORKS EDUCATIONAL VERSION

MJW

LIGHTING DESIGN

HOUSE LIGHTS: 800
 CONDUCTOR: 502 + 503
 MUSIC STAND: 501

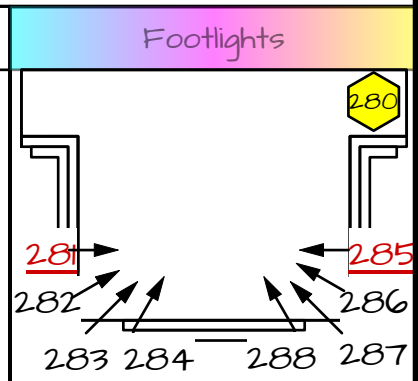
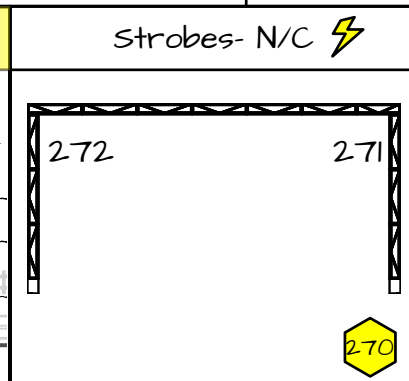
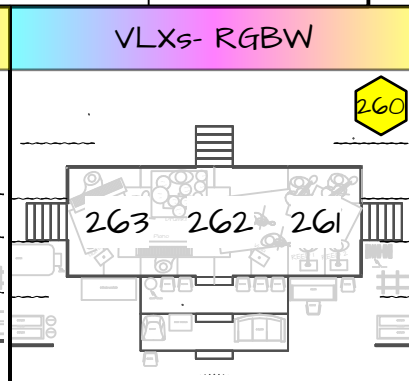
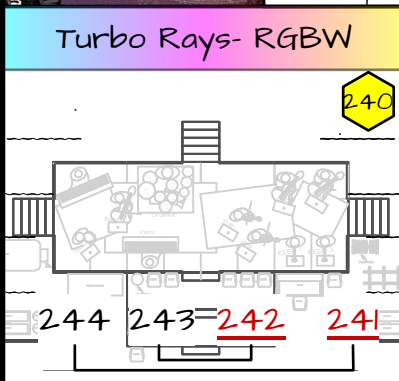

- Cyc + Audience**
- R50 -> 301 - 303 (301)
 - R82 -> 304 - 306 (304)
 - R348 -> 307 - 309 (307)
 - R24 -> 310 - 312 (310)
 - R68 -> 313 - 315 (313)
 - R20 -> 316 - 318 (316)
 - HW R24 -> 381-386 (381)
 - AB L200 -> 391-398 (391)

- Box Boom / Color Coves**
- ICove SL -> 321 - 332 (320)
 - ICove SR -> 341 - 352 (340)

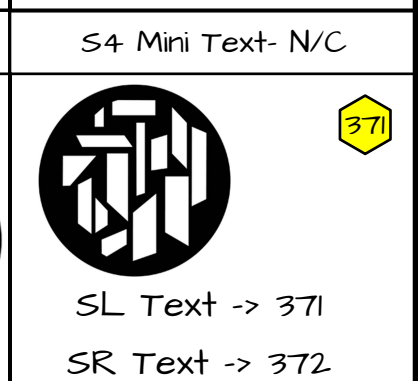
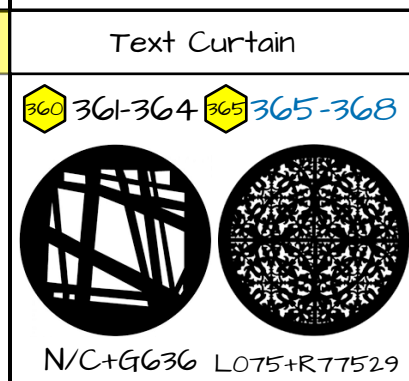

- Practicals + Specials**
- Gold Chandelier: 402 401
 - Crystal Chandelier: 403
 - MOON: 404

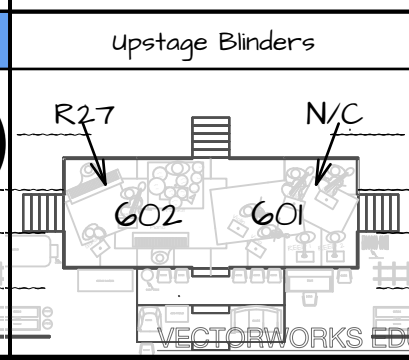
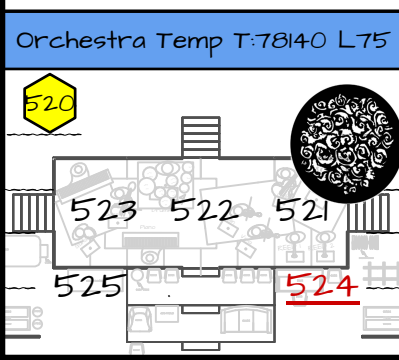
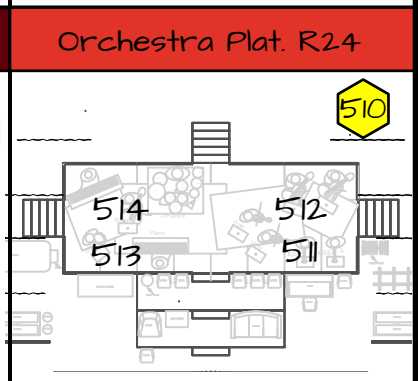
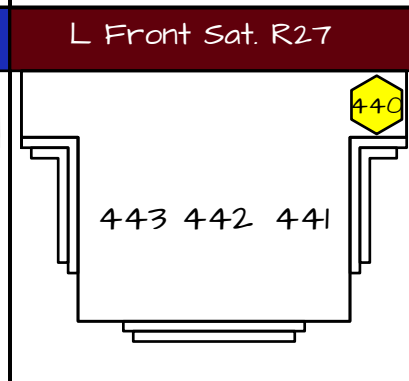
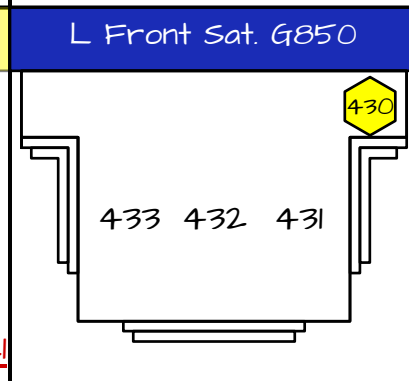
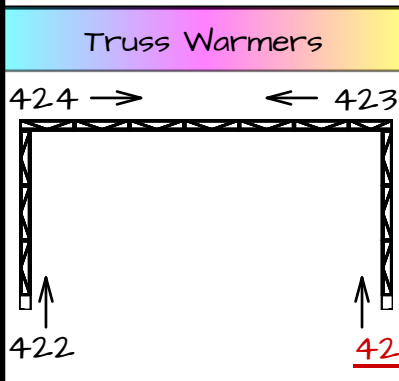
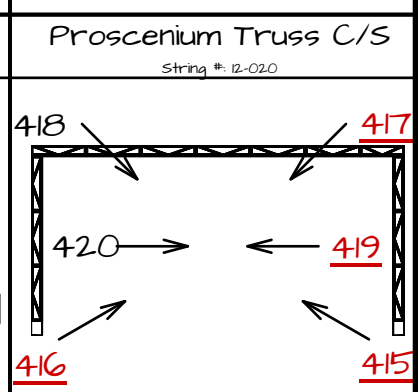
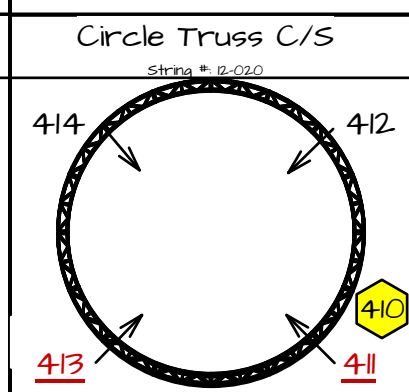

- Atmospherics**
- MDG: 611
 - Fogger: 612

TECH TABLE LIGHT:
 850

Created by: Sasha Finley and Eva Oney



LD: Matthew J. Weisgale	Carnegie Mellon University
ALD: Sasha Finley	Art: Philip Chosky Theatre
ALD: Eva Oney	REVISION
LM: Willem Hinternhoff	#1 - 3/19/22
Assoc LM: James Gallo	#2 - 4/1/22
Assist LM: Ariel Bernhard	#3 - 4/13/22
EOS Progr: Alexa Janoschka	#4

VECTORWORKS EDUCATIONAL VERSION
MJW
 LIGHTING DESIGN

HOUSE LIGHTS: 800
 CONDUCTOR: 502 + 503
 MUSIC STAND: 501

The Comet 730

731-738

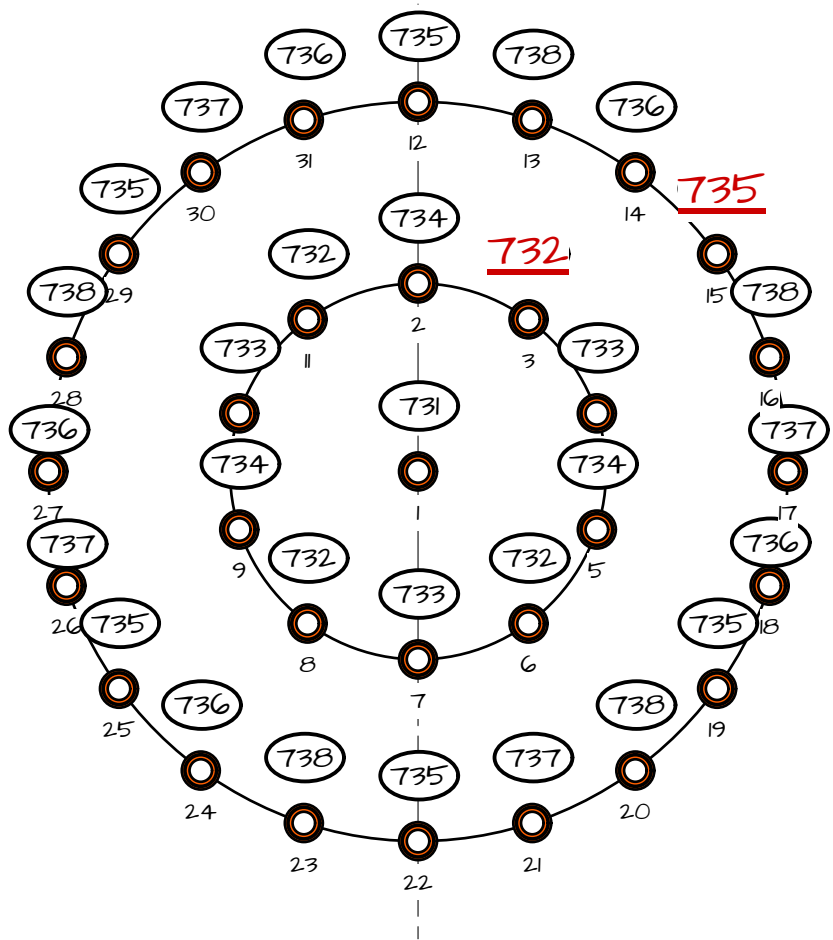

Stars 700

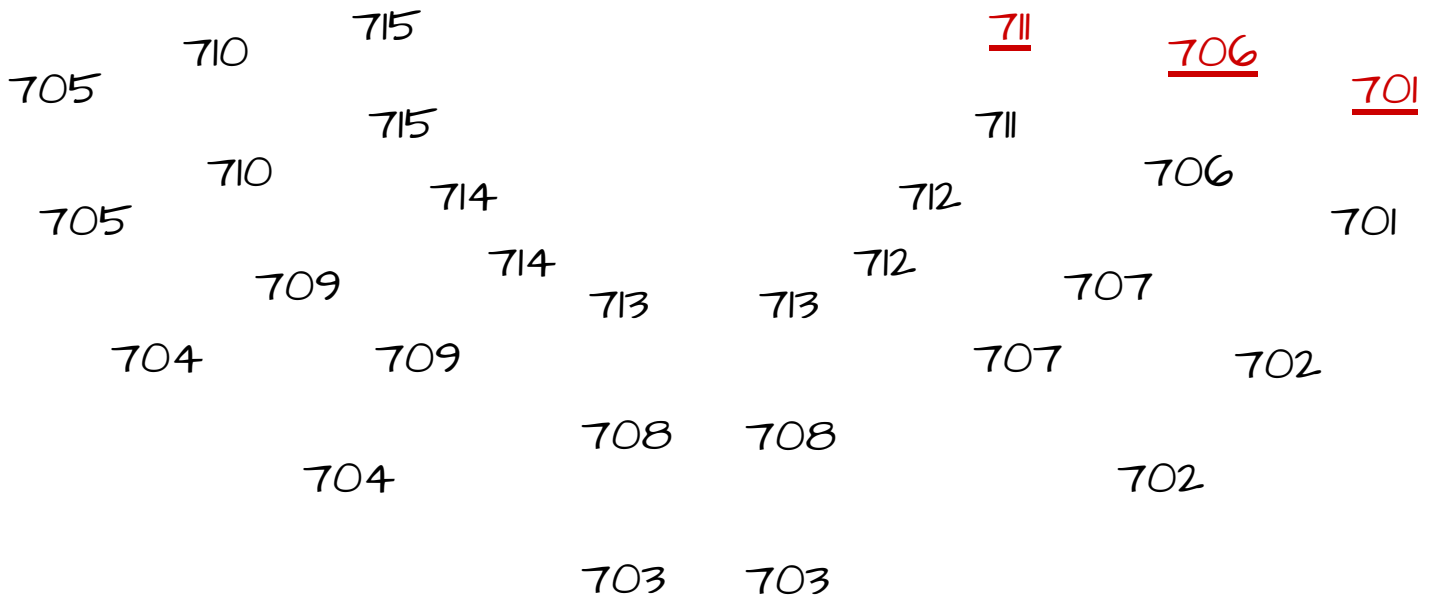



LD: Matthew J. Weisgale	Carnegie Mellon University
ALD: Sasha Finley	AT: Philip Chosky Theatre
ALD: Eva Oney	REVISION
LM: Willem Hinternhoff	#1- 3/19/22
Assoc LM: James Gallo	#2 - 4/1/22
Assist LM: Ariel Bernhard	#3 - 4/13/22
EOS Progr: Alexa Janoschka	#4

VECTORWORKS EDUCATIONAL VERSION

MJW

LIGHTING DESIGN

HOUSE LIGHTS: 800
CONDUCTOR: 502 + 503
MUSIC STAND: 501

I: 2I-010

Wybron ColoRam 4"

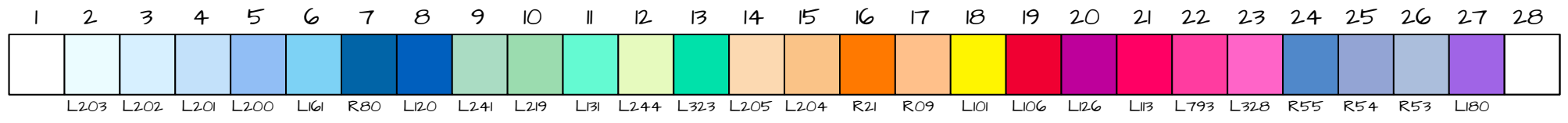

I: 12-020

Wybron ForeRunner 7"

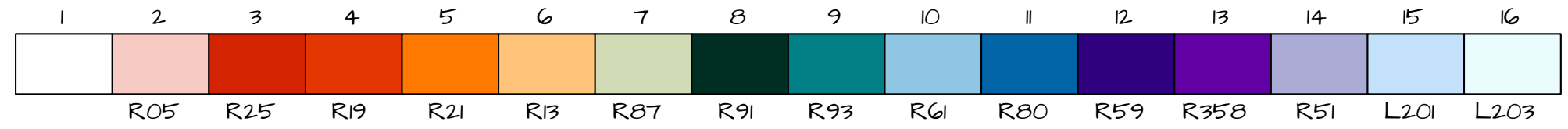

#1: SolidFrame Theatre Wheel 1

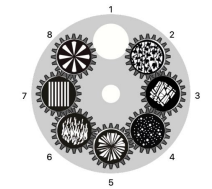

Description	Rotates	Type	Gobo Size	Count
1 Open	No	Open	No	No
2 Foliage	Yes	Gobo	No	No
3 Fracture	Yes	Gobo	No	No
4 Xylern	Yes	Gobo	No	No
5 Valent	Yes	Gobo	No	No
6 Fire	Yes	Gobo	No	No
7 Bars	Yes	Gobo	No	No
8 Pin Wheels	Yes	Gobo	No	No

#2: SolidFrame Theatre Wheel 2

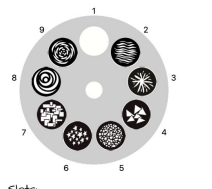

Description	Rotates	Type	Gobo Size	Count
1 Open	No	Open	No	No
2 Waves	No	Gobo	No	No
3 Splash	No	Gobo	No	No
4 Triangles	No	Gobo	No	No
5 Polymkba	No	Gobo	No	No
6 Stars	No	Gobo	No	No
7 Modern	No	Gobo	No	No
8 Crescents	No	Gobo	No	No
9 Twist	No	Gobo	No	No

#3: SolidFrame Theatre Wheel 3

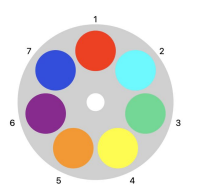

Description	Rotates	Type	Gobo Size	Count
1 Red	No	Color	No	No
2 Blue	No	Color	No	No
3 Green	No	Color	No	No
4 Yellow	No	Color	No	No
5 Orange	No	Color	No	No
6 Purple	No	Color	No	No
7 Dark Blue	No	Color	No	No

#4: VariLite 3500 Wheel 1

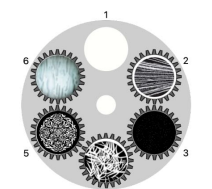

Description	Rotates	Type	Gobo Size	Count
1	No	Open	No	No
2 Alphas Rays	Yes	Gobo	No	No
3 Night Sky	Yes	Gobo	No	No
4 Tribal	Yes	Gobo	No	No
5 Antique Rosette	Yes	Gobo	No	No
6 Glacier Flag	Yes	Gobo	No	No

#5: VariLite 3500 Wheel 2

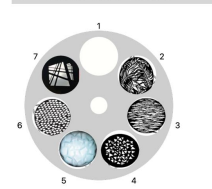

Description	Rotates	Type	Gobo Size	Count
1 Open	No	Open	No	No
2 Palm Leaves	No	Gobo	No	No
3 Shock Break-up	No	Gobo	No	No
4 Triangle Break-up	No	Gobo	No	No
5 Ice Blocks	No	Gobo	No	No
6 Pebbles	No	Gobo	No	No
7 Industrial	No	Gobo	No	No

#7: VariLite 3500 Color Wheel 1

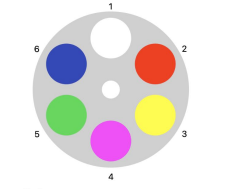

Description	Rotates	Type	Gobo Size	Count
1	No	Open	No	No
2 Red	No	Color	No	No
3 Yellow	No	Color	No	No
4 Magenta	No	Color	No	No
5 Kelly Green	No	Color	No	No
6 Congo Blue	No	Color	No	No

#8: VariLite 3500 Color Wheel 2

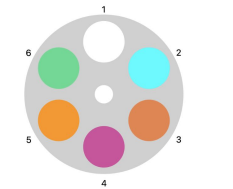

Description	Rotates	Type	Gobo Size	Count
1 Blue	No	Open	No	No
2 Blue	No	Color	No	No
3 Amber	No	Color	No	No
4 Dark Fuchsia	No	Color	No	No
5 Orange	No	Color	No	No
6 Green	No	Color	No	No

#6: Bad Boy Wheel 1

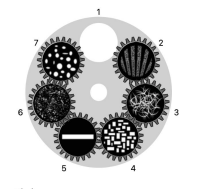

Description	Rotates	Type	Gobo Size	Count
1	No	Open	No	No
2 Cardboard Texture	Yes	Gobo	No	No
3 Bramble Breakup	Yes	Gobo	No	No
4 Less Squares	Yes	Gobo	No	No
5 Slot	Yes	Gobo	No	No
6 Pencil Dust	Yes	Gobo	No	No
7 Just Holes	Yes	Gobo	No	No

#9: Bad Boy CT Wheel

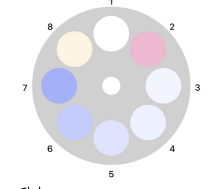

Description	Rotates	Type	Gobo Size	Count
1	No	Open	No	No
2 Minus Green	No	Color	No	No
3 1/8 CTB	No	Color	No	No
4 1/4 CTB	No	Color	No	No
5 1/2 CTB	No	Color	No	No
6 3/4 CTB	No	Color	No	No
7 Full CTB	No	Color	No	No
8 1/8 CTO	No	Color	No	No